

LED Light Box - Magnetic Frame (MF-02 - Single-Sided)

Our CSA-approved Magnetic Frame light boxes provide a modern take on display frames. Powered by innovative, power-saving technology, these silver array aluminum frames are a great way to promote your business or brighten up your home. These slim light boxes are one of the more stylish designs available on the market and combined with its low-profile delivers a stunning and sleek look. Graphics can be easily changed by using a simple suction cup (in box) allowing the user to pull open the front panel to change images with ease.

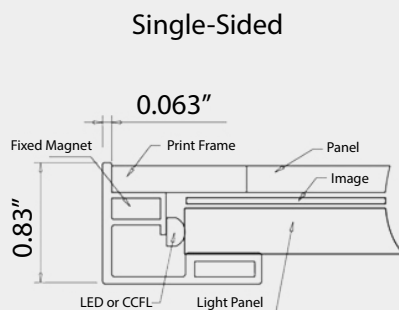
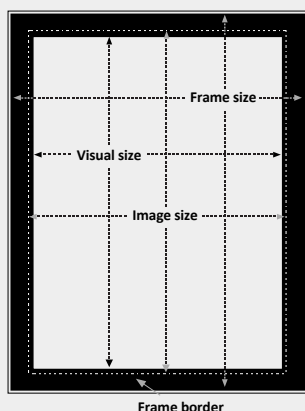
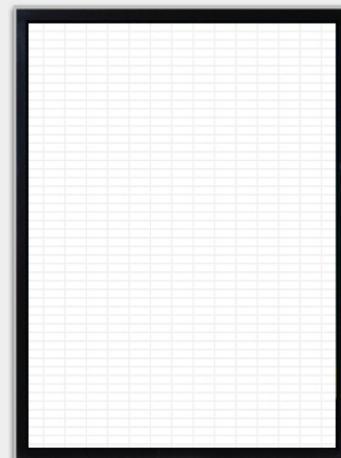

Accessories

- 1 x Magnetic Frame LED Light Box
- 1 x Power Adapter
- 1 x Dimmer

NOTE: The 16" L x 20" W Magnetic Frame does not have a dimmer included.

Available in sizes

- 16" L x 20" W, 20" L x 24" W,
- 20" L x 30" W, 24" L x 36" W,
- 36" L x 48" W.

Model Number	Frame Size L x W x H (inch)	Image Size L x W (inch)	Visual Size L x W (inch)	Weight (lbs)	Type of Tube	Power Supply
MF-02-SF-A1	36 x 48 x 0.83	34.1 x 46.1	33.5 x 45.5	25	LED 38W	AC 110-230V 50Hz/60Hz
MF-02-SF-A2	24 x 36 x 0.83	22.3 x 34.3	21.5 x 33.5	16	LED 32W	AC 110-230V 50Hz/60Hz
MF-02-SF-A4	20 x 30 x 0.83	18.3 x 28.3	17.5 x 27.5	12	LED 18W	AC 110-230V 50Hz/60Hz
MF-02-SF-A5	20 x 24 x 0.83	18.3 x 22.3	17.5 x 21.5	11	LED 16W	AC 110-230V 50Hz/60Hz
MF-02-SF-A6	16 x 20 x 0.83	14.3 x 18.3	13.5 x 17.5	8	LED 12W	AC 110-230V 50Hz/60Hz



Clear Frame (Wall Suspension)



Clear Frame (Wall Mount/Countertop)

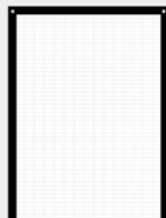

Glossy Black Frame (Wall Mount/Countertop)

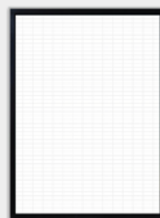

Magnetic Frame (Wall Mount)



Magnetic Frame (Wall Suspension)



Snap Frame (Wall Mount)